

Design guidelines

Railway Energy

Part 1: traction power system

09-05-2022



Co-financed by the European Union
Connecting Europe Facility

*The sole responsibility of this publication lies with the author.
The European Union is not responsible for any use that may be made of the information contained therein.*

Table of Contents

1.	Regulations, Codes, Standards, and Guidelines.....	4
1.1.	European Standards:.....	4
1.2.	International Electro-Technical Commission (IEC) Standards.....	4
1.3.	Institute of Electrical and Electronics Engineers (IEEE) Standards.....	5
2.	Overview and General Design Criteria.....	6
2.1.	Traction Electrification System.....	6
2.2.	Description of Traction Electrification System.....	6
2.3.	General Design Requirements.....	7
2.3.1.	Safety Design.....	7
2.3.2.	Product Selection.....	7
2.3.3.	Uniformity.....	7
2.3.4.	Environmental Conditions.....	8
2.4.	Interfaces with other subsystems.....	8
2.5.	Performance Requirements.....	8
3.	Design Criteria.....	11
3.1.	System Configuration.....	11
3.2.	Traction Power Substations.....	12
3.3.	HV Utility Grid interface.....	13
3.4.	Sectioning Parallel Post SPP.....	14
3.5.	Paralleling Posts PP.....	16
3.6.	Electrical Protection Coordination.....	18
3.6.1.	General requirements.....	18
3.6.2.	Electrical Protection TPS requirements.....	18
3.6.3.	Electrical Protection Scheme for OCS Fault Detection.....	19
3.7.	Lightning system.....	20
3.8.	Earthing and bonding system.....	20
3.8.1.	General requirements.....	20
3.8.2.	TPS earthing and bonding system.....	21
3.9.	ECCS energy command and control system.....	21
3.10.	Non-traction power system.....	24
3.11.	Protection against fire.....	24
3.11.1.	General fire protection rules.....	24
3.11.2.	Additional fire protection rules for transformers.....	24
3.12.	Electromagnetic compatibility.....	26

3.12.1.	Best practices	26
3.12.2.	Limits exposures	27
3.13.	Traction Power Facilities and Associated Sites	28

1. Regulations, Codes, Standards, and Guidelines

The design shall comply with following mandatory regulations, codes and standards:

1.1. European Standards:

- EN 50119 - Railway applications - Fixed installations - Electric traction overhead contact lines
- EN 50121-1 - Railway applications – Electromagnetic Compatibility
- EN 50122-1 - Protective Provisioning Relating to Electrical Safety and Earthing
- EN 50122-3 - Railway applications – Fixed installations – Electrical safety, earthing and the return circuit. Mutual Interaction of a.c. and d.c. traction systems (see Note 1)
- EN 50124-1 - Railway applications – Insulation Coordination
- EN 50124-2 - Railway applications – Overvoltage and Related Protection
- EN 50152 - Railway Applications–Fixed Installations–Particular Requirements for ac Switchgear Part 1: Single-phase circuit-breakers with Um above 1 kV Part 2: Single-phase disconnectors, earthing switches and switches with Um above 1 kV.
- EN 50160 - Voltage Characteristics of Electricity Supplied by Public Distribution Systems
- EN 50163 - Railway Applications – Supply Voltages of Traction Systems,
- EN 50329 - Railway Applications – Fixed Installations – Traction Transformers
- EN 50388 - Railway Applications – Power Supply and Rolling Stock – Technical Criteria for the Coordination Between Power Supply (Substation) and Rolling Stock to achieve Interoperability
- EN 61936-1 - Power installations exceeding 1 kV AC - Part 1: Common rules
- EN 62305 Protection against lightning - Part 1: general principles
- ICNIRP Guidelines - Guidelines for limiting exposure to time-varying Electric, magnetic, and electromagnetic fields

Note 1: This standard shall be fulfilled when the Rail Baltica line lies in parallel with existing DC electrified railway in operation (cities approach for instance – chainages to be checked by the designer)

1.2. International Electro-Technical Commission (IEC) Standards

- IEC 60056 – A.C. High Voltage Circuit Breakers
- IEC 60076 – Power Transformers
- IEC 60099-4 – Surge Arresters
- IEC 60298 – A.C. Metal-Enclosed Switchgear and Control gear for Rated Voltages Above 1 kV and Up to and Including 52 kV
- IEC 60332-1-2 Tests on electric and optical fibre cables under fire conditions - Part 1-2: Test for vertical flame propagation for a single insulated wire or cable - Procedure for 1 kW pre-mixed flame
- IEC 60694 – Specifications Common for High Voltage Switchgear and Control gear Standards
- IEC 62271 – High-Voltage Switchgear and Control gear

1.3. Institute of Electrical and Electronics Engineers (IEEE) Standards

- IEEE 80 – IEEE Guide for Safety in AC Substation Grounding
- IEEE 242 – IEEE Recommended Practice for Protection and Coordination of Power Systems
- IEEE 485 – IEEE Recommended Practice for sizing Large Lead Storage Batteries for Generating Stations and Substations
- IEEE 519 – IEEE Recommended Practices and Requirements for Harmonic Control in Electrical Power Systems
- IEEE 1427 – IEEE Guide for Recommended Electrical Clearances and Insulation Levels in Air-Insulated Electric Power substations

2. Overview and General Design Criteria

2.1. Traction Electrification System

A Traction Electrification System (TES) is the combination of the TPS, OCS, and the traction power return system, together with appropriate interfaces to the TES-related supervisory control and data acquisition system (ECCS Energy command and control system). It forms a fully functional 2x25 kV ac traction power supply and distribution system and provides the traction power to the electrically powered vehicles on the high-speed railway line.

The Traction Power Supply System (TPS) is based upon a 50 hz, 2x25 kilovolt (kV) autotransformer feed configuration. Traction substations shall be based on SFC (static frequency converter) technology: each traction substation is composed of 2 SFC systems.

SFC system is meant as the complete set of equipment whose input is a 3ph high voltage feeder and on the output side it provides the traction power to the catenary system. The principle scheme of the TSS is represented in §3.2, the SFC systems (SFC system 1 and SFC system 2) are represented as orange boxes. The configuration of the SFC system could be different depending on the specific technology and manufacturer, but conceptually it is composed of input/output transformers, power electronic converters, filters, cooling system, control system.

The function the SFC system in the SFC-based TSS is, conceptually, the same of the traction transformers in a traditional substation.

Local grid requirements shall be considered in the design of TPS. Detailed requirements shall be discussed with local energy infrastructure manager.

2.2. Description of Traction Electrification System

Traction Power Substations (TSS) – An electrical installation where power is received at high voltage and transformed to the voltage and characteristics required at the catenary and negative feeders for the nominal 2x25 kV system, containing equipment such as SFC systems, circuit breakers and sectionalizing switches. It also includes the incoming lines from the power supply utility.

Paralleling Posts (PP) – An installation that helps boost the Overhead contact system OCS voltage and reduce the running rail return current by means of the autotransformer feed configuration. The Negative Feeder (NF) and the catenary conductors are connected to the outer terminals of the autotransformer winding at this location with the central terminal connected to the rail return system.

Sectioning Paralleling Posts (SPP): these facilities are parallel posts installed in correspondence of OCS sectioning.

Traction power system (TPS) - A Traction Power System (TPS) is the combination of the TSS, SPP and PP.

Overhead contact line system (OCS): A system that distributes the electrical energy to the trains running. The overhead contact line system is also equipped with manually or remotely controlled disconnectors which are required to isolate electrical sections according to operational necessity. Feeder lines are also part of the overhead contact line system;

Traction Power Return System – A traction power return system refers to all conductors including the grounding system for the electrified railway tracks, which form the intended path of the traction return current from the wheel-sets of the traction units to the substations under normal operating conditions and the total return current under fault conditions. The conductors may be of the following types:

- Running rails;
- Impedance bonds;
- Aerial and/or buried ground or return conductors;
- Rail and track bonds;
- Return cables, including all return circuit bonding and grounding interconnections;
- Earth;
- Negative feeders (as a consequence of the configuration of the autotransformer connections).

Electrical Section – for SFC traction technology in normal operation mode OCS is not electrically separated.

2.3. General Design Requirements

2.3.1. Safety Design

The design shall incorporate the following principles:

- Avoid, eliminate, or reduce hazards through design choices, material selection, or substitution.
- Incorporate fail-safe principles where failures could disable the system, cause human injury, damage to equipment, or inadvertent operation of critical equipment.
- Locate equipment components so that access to them by the required personnel during operation, maintenance, repair, or adjustment shall not require exposure to hazards such as electrical shock.
- Provide measures designed to prevent or discourage unauthorized persons from entering hazardous areas.

2.3.2. Product Selection

- All equipment, materials, cables shall be either certified by a nationally recognized testing laboratory, or compliant with relevant International or local standards.
- All equipment, materials, cables shall be produced by manufacturers that have a proven experience in the production of such products.

2.3.3. Uniformity

The TES shall be designed so that all components that do not differ in operational, functional, and/or performance characteristics are positioned in the same location and internal wiring is routed between components in a like manner.

Ratings and configuration for each type of TES shall be standardized to the extent practical

2.3.4. Environmental Conditions

The TES design shall ensure minimum electric energy loss in the equipment. The TPS design shall be suitable for the local environmental conditions.

2.4. Interfaces with other subsystems

The traction power system interfaces with other systems of the rail system in order to achieve the envisaged performance. These subsystems are listed below:

- Power authority;
- Rolling stock;
- Substructure;
- Superstructure;
- OCS;
- Traction Power Return System;
- Telecommunication system;
- Facilities.

The TPS design shall be addressed in order to taking into account all interfaces listed above.

In order to define the interface between TPS, OCS, rolling stock and traction power return system, the maximum overhead contact line – rail short circuit level shall be less than 15 kA.

2.5. Performance Requirements

The Traction Electrification System TES shall be designed to meet the following performance requirements:

- The maximum line speed design.
- The TES sizing shall be in accordance with the peak frequency of the planned train graph
- The system shall be designed to enable continuity of operation in case of disturbances such that all of the following are achieved:
 - There shall be no degradation of train performance in case of single electrical contingency conditions, i.e., isolation of any 1 SFC system in a traction substation, 1 autotransformer in a PP/SPP, 1 circuit breaker in TSS.
 - Degradation of train performance may be accepted in case of double electrical contingency conditions (simultaneous occurrence of more than 1 single electrical contingency condition in any electrical section). The degradation shall be defined by traffic operation study.
 - The voltage at the train’s pantograph is according to EN 50163 and EN 50388 standards.

EN 50163 - Nominal voltages and their permissible limits in values and duration

Electrification system	Lowest non-permanent voltage	Lowest permanent voltage	Nominal voltage	Highest permanent voltage	Highest non-permanent voltage
	U_{min2} V	U_{min1} V	U_n V	U_{max1} V	U_{max2} V

a.c. (r.m.s. values)	17 500 °	19 000 °	25 000	27 500 °	29 000
-------------------------	----------	----------	--------	----------	--------

- the duration of voltages between U_{min1} and U_{min2} shall not exceed 2 min;
- the duration of voltages between U_{max1} and U_{max2} shall not exceed 5 min;
- the voltage of the busbar at the substation at no load condition shall be less than or equal to U_{max1} .
- under normal operating conditions, voltages shall lie within the range $U_{min1} \leq U \leq U_{max2}$;
- under abnormal operating conditions the voltages in the range $U_{min2} \leq U \leq U_{min1}$

EN 50163 - Maximum value of the voltage U according to the duration

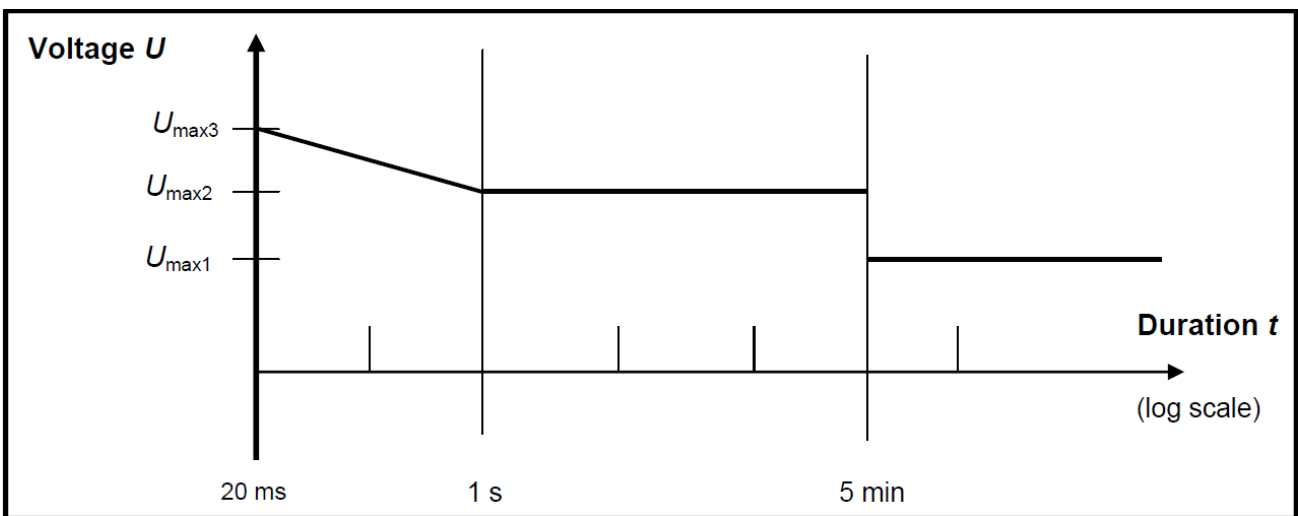

Nominal voltage U_n	25 000
V	
Coefficient k	0,074 1
U_{max1} (V)	27 500
U_{max2} (V)	29 000
U_{max3} (V)	38 750

Highest permanent voltage U_{max1} : Maximum value of the voltage likely to be present indefinitely

Highest non-permanent voltage U_{max2} : Maximum value of the voltage likely to be present as highest non-permanent voltage for a limited period of time

Highest long-term overvoltage U_{max3} : Voltage defined as the highest value of the long-term overvoltage for $t = 20$ ms. This value is independent from frequency

Coefficient K: Typical overvoltage coefficient for 25kV systems

EN 50388 - Minimum U_{mean} useful at pantograph

Power supply system	Category I, II, III HS TSI lines
	Zone and train
a.c. 25 000 V 50 Hz	22 500

U_{mean} useful at pantograph: This is the mean value of all voltages in the same simulation as the geographic zone study but only analysing the voltages for each train in the simulation at each time step where the train is taking traction load (ignoring steps when the trains are stationary, regenerating or coasting).

- The frequency of the 50 Hz electric traction system is imposed by the three-phase grid. Therefore, the values stated by EN 50160 are applicable
- The heating dimensioning of OCS shall be according to EN 50119 standard
- The heating power transformer shall be in accordance with EN 50329 and IEC 60076 Standards
- The TES and the associated OCS shall be designed to permit the use of regenerative braking. The use of regenerative braking shall be facilitated by 1 or both the following:
 - Transfer of braking energy back into the OCS for use by another train(s) that is (are) drawing power from the OCS and is (are) located in the same electrical section as the braking train
 - Transfer of braking energy back to the power supply utility company's network in case trains in the same electrical section do not draw the full regenerated power.

General conditions on the use of regenerative braking are given in chapter 12 of EN 50388.

Setting protection in substation shall be carried out in order to permit regenerative braking

- TPS Lifetime: please refer to RBDG-MAN-012 general requirements

3. Design Criteria

3.1. System Configuration

The configuration of the TES and distribution system shall be confirmed by a computer-based traction power load flow study.

The architecture of the traction power system is resumed by the following characteristics:

- type of electrification: 2x25 kV;
- frequency: 50 Hz;
- traction substations (TSS): traction power is delivered to the catenary through SFC systems. In each TSS, 2 SFC systems shall be installed. The sizing of the SFC systems shall be such that in case one SFC system is out of service, the other SFC system can provide the total requested power, without affecting traffic services. Same principle applies to HV feeder lines: two HV feeder lines shall be foreseen in each TSS, and relevant sizing and configuration shall be such that in case on HV feeder is out of service, the other one can provide the total requested power, without affecting traffic services;
- respect to traditional substations, SFC-based substations shall perform a parallel feeding of the OCS (neutral sections are not needed);
- 2x25 kV is realized through autotransformers feeding, autotransformers are installed in Parallel Posts (PP) and Sectioning Parallel Post (SPP);

The following criteria shall be taken into account:

- TSS sites should be located taking into account the interface with the national Transmission System Operators
- SPP sites shall be located approximately midway between adjacent SS sites.
- PP sites should be located at approximately 15 km intervals between TSS sites.
- The track grades at the neutral section and to 2 km on either side shall not be greater than 0.5 % (where needed in specific cases).
- TPS facilities shall not be located in tunnel.

3.2. Traction Power Substations

The number, the locations of the TSS and the power of transformers shall be determined based on the results of a traction power study.

The **simplified** traction power substation's single-line diagram is shown in figure 1.

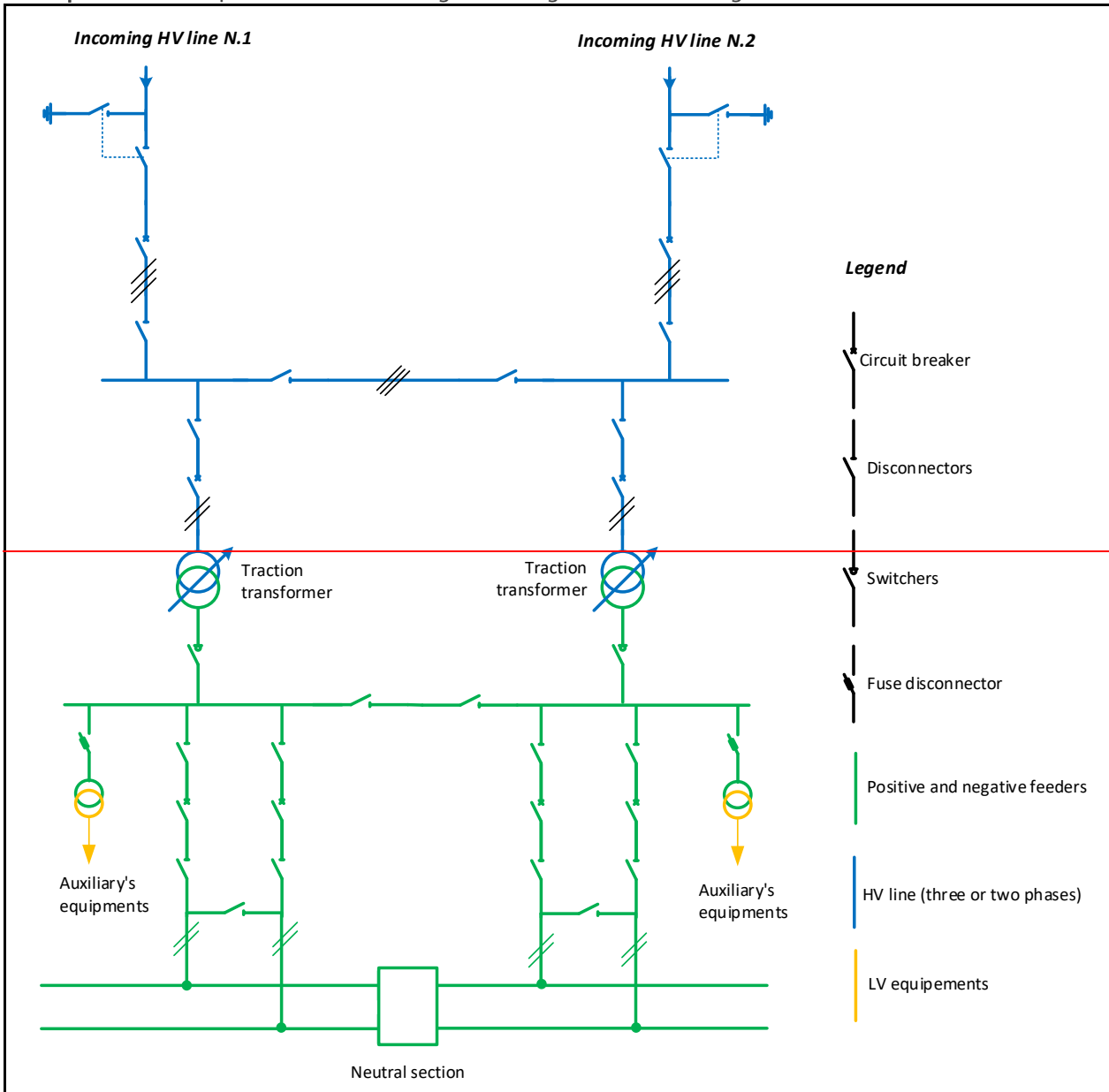

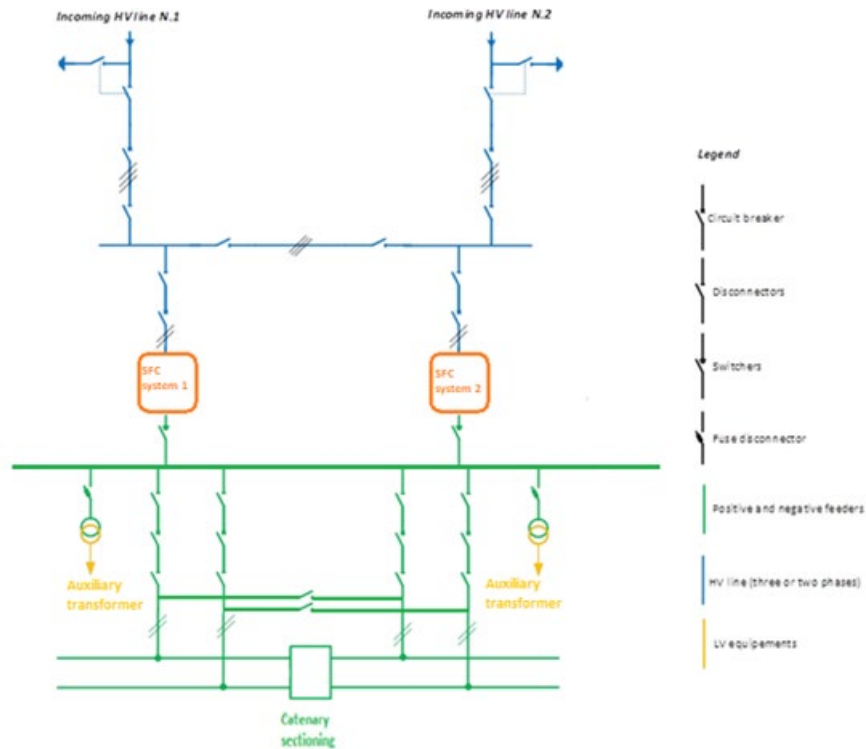

Figure 1 - Simplified traction power substation's single-line diagram

For overhead contact line system arrangement refer to RBDG-MAN-019 Railway Energy Part 2 catenary.

For auxiliary power supply, refer to RBDG-MAN-020 Railway Energy Part 3 Non-traction power supply.

A de-icing OCS system shall be provided.

All HV switchgears shall be outdoor type.

According to the specific SFC technology, the SFC system shall be designed in order to provide a 2x25kV output voltage (3-poles: +25kV, 0kV, -25kV).

The autotransformer winding centre tap shall be locally grounded and connected also to the running rails of both tracks (through impedance bonds if present, according to signalling design).

As shown in figure 1, the traction power substation's single-line diagram, reconfiguration capabilities and sizing shall be such that in the event of a power loss to 1 of the incoming HV feeder lines, or temporary outage of 1 of the SFC system, the remaining equipment shall be able to supply power to the feed sections north and south of the TSS.

3.3. HV Utility Grid interface

Different feeding arrangements on the HV side include direct feed from a utility substation or loop-in-loop-out feeding arrangement from its HV transmission network. The specific feeding arrangement at any TSS depends on site-specific conditions, the configuration of the power utility company's network at that location, and the policies/procedures of the power utility company.

Because of this, **the HV connection scheme shall be approved by power authority.**

In traditional substations with transformers, the load imposed by the railway's traction power substations on the electric utility's 3-phase, will be single-phase, nonlinear and rapidly variable over time. Since each HV transformer will draw power from only 2 phases of a 3-phase system, some current and voltage imbalances will inevitably be caused in the HV supply grid. This problem does not exist with the SFC technology: SFC are symmetrical loads, so they can be supplied from extreme weak electrical grids, because, in this case, it is not necessary to have a high short-circuit power in the feeding point of the electrical grid. Thus, being allowed to connect to lower-voltage nodes in the electrical public grid.

In any case, the limitations imposed by TSO shall be verified and respected.

As a rule, the railway load is characterized by following factors:

- Phase unbalance caused by the single-phase nature of the load.
- Voltage flicker, caused by the highly variable nature of the load.
- Harmonic distortion, produced by the power convertors on the trains.

Particular configurations of overhead contact system may be considered as long inductive line. It can consume unnecessary energy by phase-shifting the current behind the fundamental voltage. The harmful consequences of reactive power are:

- It increases the necessary current at the risk of causing overcurrents and problematic voltage drops leading to the need to oversize the conductors.
- It reduces the available active power, which limits the possibilities of using the source or requires it to be oversized.
- It generates an additional operating cost connected with the pricing of the reactive energy consumed and measured by the distribution company.

The simulation traction power supply system, on the basis of the OCS configuration and load traffic, shall evaluate the entity of this reactive power.

The TPS design shall address power quality issues, such as voltage imbalance, voltage flicker, high power factor and harmonic distortion caused by the railway load on the HV supply system, arising from operation. International Standards EN 50160, EN 50163 and EN 50388 shall be taken into account.

In order to achieve electrical system compatibility, harmonic overvoltage shall be limited below critical values according to EN 50388:2012, clause 10.4.

The mitigation measures shall be submitted to the power Authority for review.

3.4. Sectioning Parallel Post SPP

The number, the locations of the SPP and the power of AT shall be determined based on the results of a traction power study.

The SPP ensure the same function of a PP, the only difference is that the SPP is installed in correspondence of overhead contact line sectioning.

The simplified traction power single line diagram is shown in figure 2.

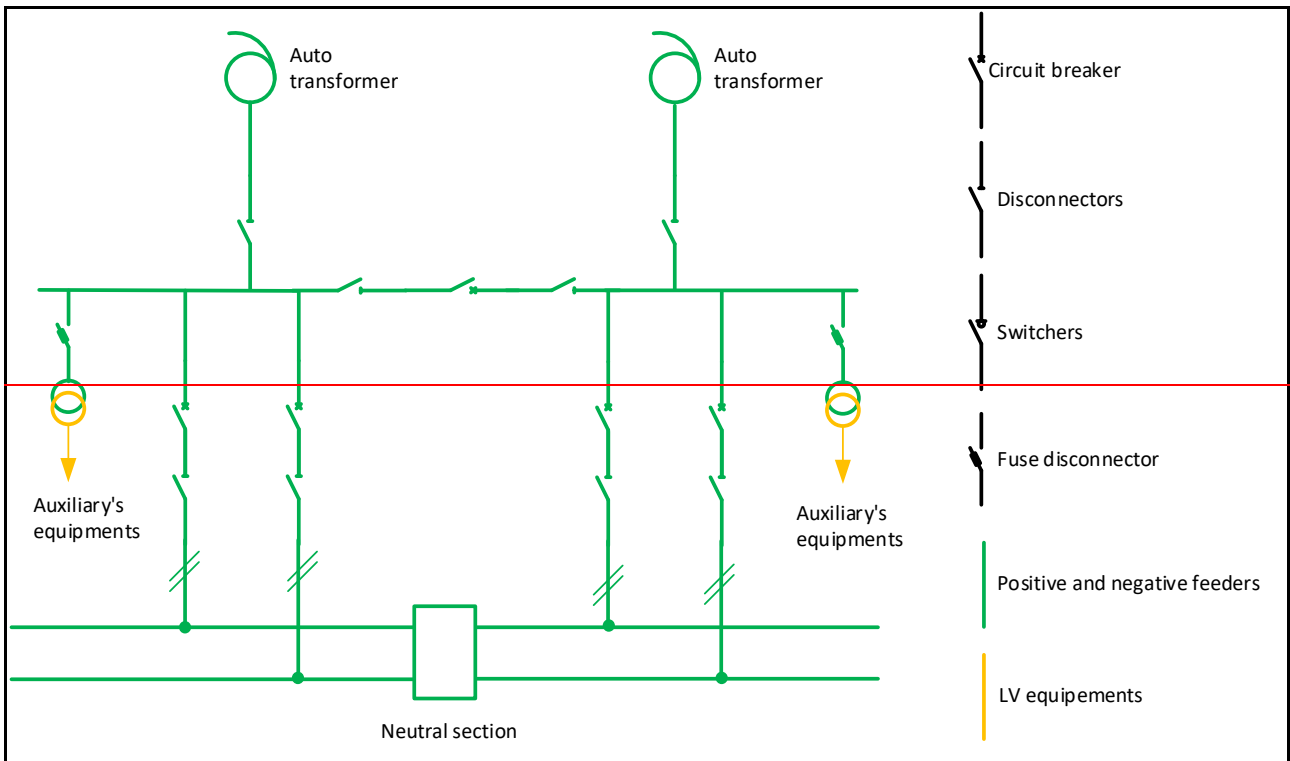

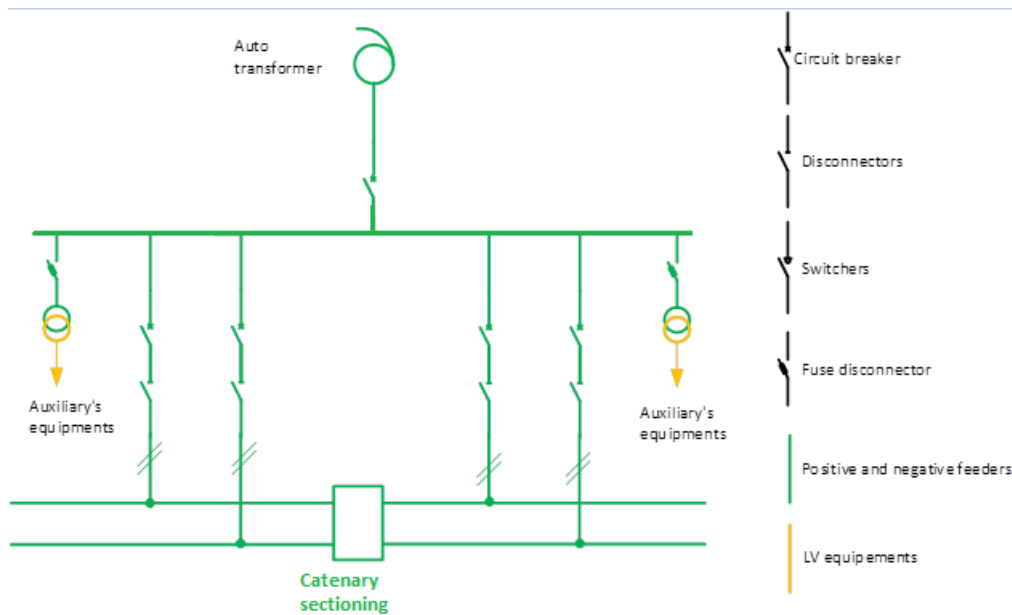

Figure 2 - Simplified traction power *SWPSP* single-line diagram

The AT winding centre tap shall be locally grounded and connected also to the running rails of both tracks (through impedance bonds as required if present, according to signalling design).

On catenary side, by-pass switches shall be installed to connect north and south of the overhead contact line sectioning.

For overhead contact line system arrangement refer to RBDG-MAN-019 Railway Energy Part 2 overhead contact line system.

For auxiliary power supply, refer to RBDG-MAN-020 Railway Energy Part 3 Non-traction power supply.

3.5. Paralleling Posts PP

The number, the locations of the PP and the power of AT shall be determined based on the results of a traction power study.

The Paralleling Posts (PP), is a facility featuring that helps boost the OCS voltage and reduce the running rail return current by means of the autotransformer feed configuration. The AT installed along the line in the PP steps down the

50 kV nominal voltage between catenary and negative feeder to the 25-kV level between catenary and running rails.

The simplified traction power single line diagram is shown in figure 3.

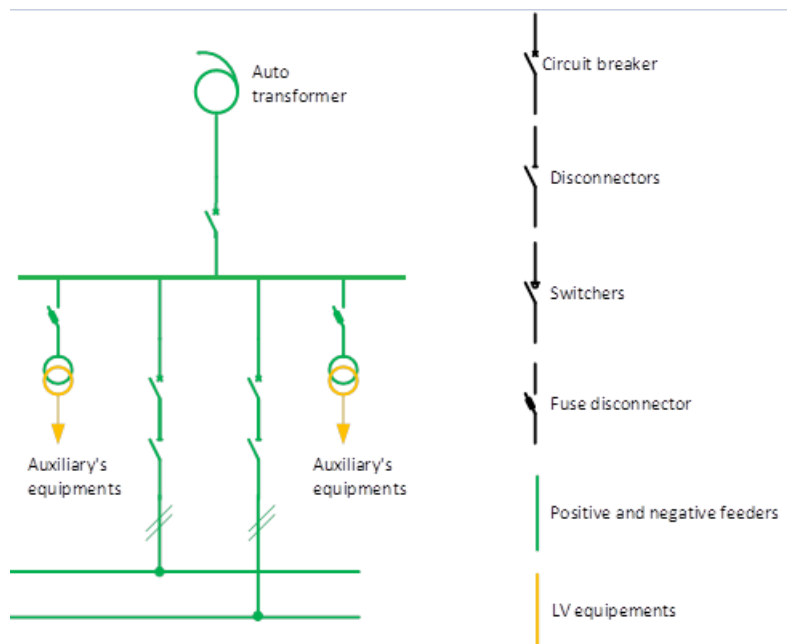
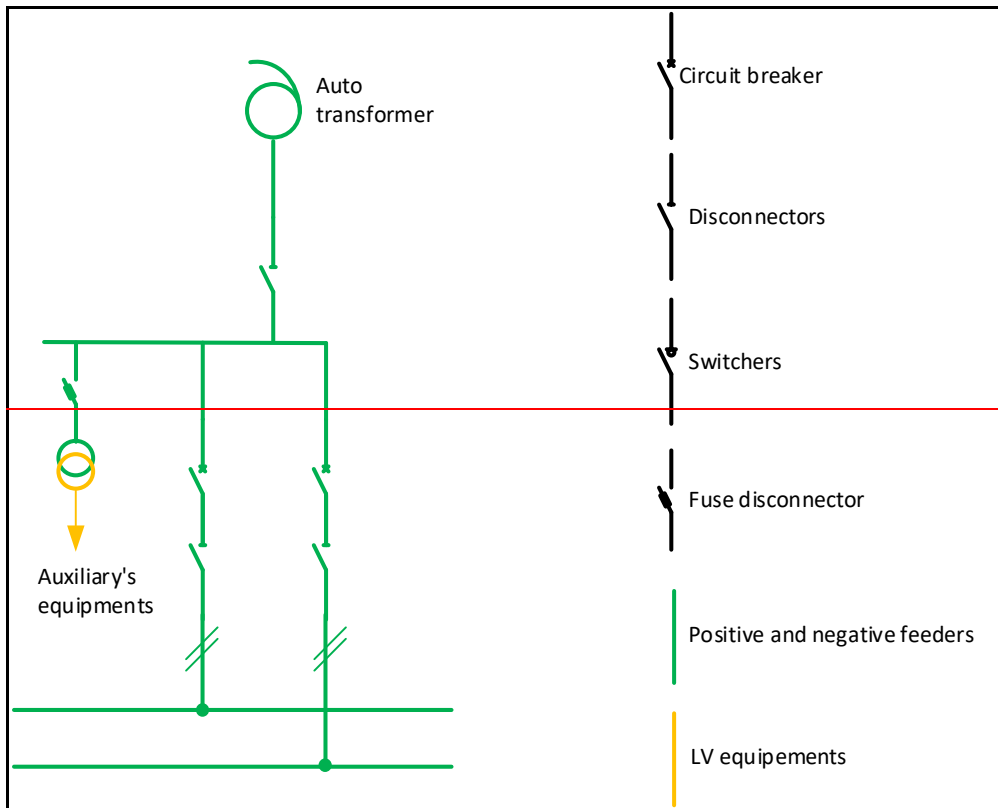

Figure 3 - Simplified traction power PP single-line diagram

The AT winding centre tap shall be locally grounded and connected also to the running rails of both tracks (through impedance bonds as required if present, according to signalling design).

For overhead contact line system arrangement refer to RBDG-MAN-019 Railway Energy Part 2 overhead contact line system.

For auxiliary power supply, refer to RBDG-MAN-020 Railway Energy Part 3 Non-traction power supply.

3.6. Electrical Protection Coordination

3.6.1. General requirements

The protection system for the TES shall be designed for a maximum catenary – rails short-circuit fault current of 15 kA.

Protective systems on traction units and at substations shall be compatible. Electrical protection coordination design of the energy subsystem shall comply with the requirements detailed in EN 50388:2012, clause 11.

The design of the relay protection system shall achieve the following:

- Protect the TES equipment and cables within the TPS, OCS against short-circuit, faults, overloading, and subcomponent failures.
- Include fault location and discrimination capabilities, including automatic circuit breaker reclosing for catenary and NF (Negative Feeder) circuits.
- Provide proper coordination and selectivity for rapid fault clearance to only the affected area of the system, preventing as much as possible the loss of power to the healthy sections of the TES.
- Adequately discriminate between short-term high loads and fault conditions.

3.6.2. Electrical Protection TPS requirements

HV relay protection equipment on the primary side of the traction power substations shall be coordinated with the respective utility company as applicable.

Traction power facility is composed of several types of equipment (high voltage, SFC systems, MV and LV cables, etc.), each component shall be protected against short circuit, overloading conditions and whatever scenarios which may lead to dangerous situations or damaging of the equipment. The analysis shall consider the particular characteristics of each component and the entire facility as whole, with all the interfaces among equipment, which create an interconnected system. The TPS facility shall be provided with protective devices, including but not limited to the following:

- Overcurrent relays;
- Differential protection;
- Under-voltage / over-voltage protection;
- Ground fault protection;
- Over-temperature protection;
- Oil-level and oil-pressure protection and alarms.

OCS circuit breakers shall be provided with electronic, microprocessor-based protective relays and devices to protect against short-circuits and conductor overloading conditions. Typically, the protective relays for overhead contact line system shall include, but not be limited to, the following:

- Instantaneous and time delay overcurrent protection
- Distance protection

- Phase directional overcurrent protection
- Automatic reclosing protection

The design of the relay protection scheme shall be presented to the Authority for review.

3.6.3. Electrical Protection Scheme for OCS Fault Detection

The OCS circuit breakers shall be provided with electronic, microprocessor-based protective relays and devices to protect against short-circuits and conductor overloading conditions. Below principles apply (but not be limited to):

- protection design shall take in account the limited short circuit current capability of the SFC systems, which means the overcurrent protection may be not effective in case of short circuit faults;
- the protection shall be based on distance protection and phase directional protection;
- each circuit breaker shall be equipped with a primary and with a backup protection;
- the protection system shall be able to distinguish short circuit fault to overloading conditions;
- considering the parallel feeding, a fault can be fed from two sides (from two TSSs): if necessary, an intercropping system between TSSs shall be implemented (circuit breakers dragged);
- automatic reclosing protection shall be implemented;
- parallel posts 25 kV indoor disconnectors are equipped with under-voltage protection.

The protection system design shall consider auto reclosing function and reconfiguration procedure after the protection trips. In case of transient fault, the auto reclosing and the reconfiguration procedure shall re-establish the normal operation. In case of permanent fault, the actions to be taken are the approximating location of the fault, isolation of the faulted subsection by opening, restore of power to the healthy segments of the affected track. The protective relaying scheme shall be analysed for both normal and contingency configurations of the traction power system. The contingency configurations shall include, not limited to, the following:

- Loss of one SFC system inside the TSS (N-1 scenario);
- Loss of an entire TSS (N-2 scenario);
- Loss of circuit breaker in a TSS or PP/SPP.
- Loss of a PP or SPP;

The detailed protection scheme design shall be based on the above principles. Suggest any alternative relay protection scheme shall be submit to the client for review.

Detailed protection scheme design shall be based on the above principles. Suggest any alternative relay protection scheme shall be submit to the client for review.

3.7. Lightning system

Please refer to RBDG-MAN-020 Railway Energy Part 3 Non-traction power supply.

An assessment of the risks presented by lightning shall be carried out in accordance with the standards of series EN 62305. If necessary, a lightning protection system shall be erected.

Overvoltages of atmospheric origin transmitted by the overhead supply system shall be taken into account when the installation is designed.

Equipment and receivers shall not be subject to voltages exceeding their lightning impulse withstand levels.

Where the installation is supplied by an overhead system, lightning arresters shall be installed at the supply terminals at least.

Additional lightning arresters are usually required at the terminals of the power transformers.

Particular attention shall be paid to the impedance of the earthing connection of the lightning arresters, which shall be as low as possible in order to avoid reducing their effectiveness.

Particular attention shall be paid to the Scada System, in order to protect all sensitive equipment by overvoltage disturbances.

3.8. Earthing and bonding system

3.8.1. General requirements

The TES design presupposes running rails electrically insulated from ground but connected to ground regularly. The connexions to ground shall be carried out using the neutral point of impedance bonds:

- to OCS ground wires (aerial and/or buried);
- At each TSS, SPP, PP locations.

The connection between running rails and OCS ground wires shall be in accordance to signalling diagram.

A part of the return current will flow through the running rails because they are part of the traction return system. Because of the impedance of the rails, this return current flow will cause a voltage with respect to the ground especially at locations away from the ground connections. Electrical safety of the TPS shall be achieved by the following means:

- The installations shall be designed and tested such that the permissible touch voltages caused by the traction system under fault conditions or in operating conditions shall not exceed values specified in the EN 50122 Standard.
- Each TSS, SPP, and PP shall be connected to the running rails by at least 2 return cables. Each return cable shall be of sufficient size to carry the maximum load current, thereby allowing for the failure of 1 return cable. The connection to the running rails is through impedance bonds (if present, according to signalling design).
- All TSS, SPP, and PP shall be fenced against unauthorized access.
- The grounding of TSS, SPP, and PP shall be integrated into the general grounding of OCS system for mitigating electric shock.

In direct proximity to operational DC railway, earthing and bonding solutions of all metallic structures shall be compatible with DC railway as well, and fulfill requirements of EN 50122-3.

3.8.2. TPS earthing and bonding system

An earthing system in TSS, SPP and PP is generally composed of several horizontal, vertical or inclined electrodes, buried or driven into the soil by force. The use of chemicals to reduce soil resistivity is not recommended.

Horizontal earth electrodes are preferably buried at a depth of 0,5 m to 1 m below ground level. This gives sufficient mechanical protection.

The following requirements shall be taken into account:

- The earthing system, its components and bonding conductors shall be capable of distributing and discharging the fault current without exceeding thermal and mechanical design limits based on backup protection operating time.
- All the sub-system of the earthing & bonding shall be able to be tested during the operations separately
- The earthing system shall maintain its integrity for the expected installation lifetime with due allowance for corrosion and mechanical constraints.
- Minimum cross-sections shall be calculated taken into account mechanical strength, stability against corrosion and thermal strength.
- Earthing system performance shall avoid damage to equipment due to excessive potential rise, potential differences within the earthing system and due to excessive currents flowing in auxiliary paths not intended for carrying parts of the fault current.
- The earthing system, in combination with appropriate measures, shall maintain step, touch and transferred potentials within the voltage limits, according to EN 50522 standard, based on normal operating time of protection relays and breakers.
- All metal frameworks shall be connected to earthing system.

3.9. ECCS energy command and control system

The ECCS (energy control and command system) ~~Local-Scada~~ is a modular system for communication, control and integration of each part of TPS system. The ECCS shall allow required interactions between different equipment of a traction power substation using common International power network protocols and/or standard industrial network protocols (such as IEC 61850, IEC 60870-5-101/104, DNP 3.0, Modbus-TCP, Profinet) and serial protocols (Modbus-RTU, Profibus-DP).

Integration provides a hierarchy of control:

- Local Compartment - data are collected directly on the switchboard
- Traction Power facilities - the information is concentrated in the facility supervision system that controls the plant
- Remote control - using protocol communication signals, alarms and commands are exchanged

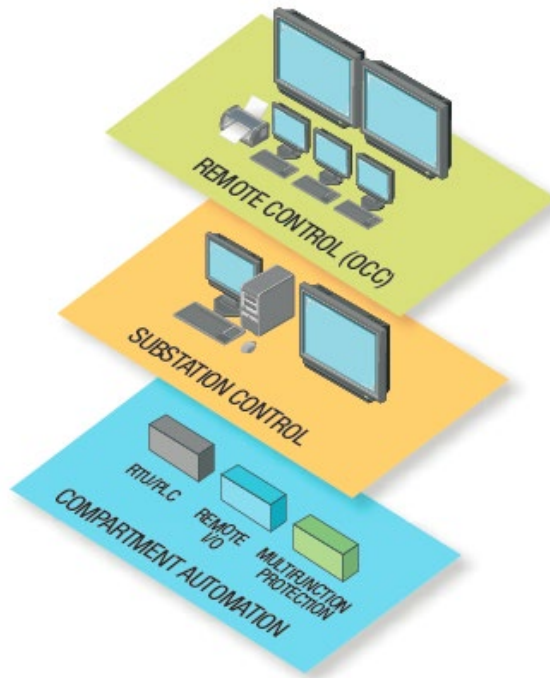

Location of remote control places shall be indicated by the client.

The integration starts from the local compartment where PLC / RTU and relay protections are installed for local acquisition, control, and protection connected to a Substation local network by means of buses and switches. This configuration allows data transmission to the station control system. Also, IED (Intelligent Electronic Device) devices are interconnected to the system.

The typical architecture for traction power substation provides Hot-Stand by RTU that are the front-end to the field and the remote-control computer for the operator interface.

Same principles are applied to parallel posts (PP) and sectioning parallel posts (SPP).

In CCS facilities, there could be need for an ECCS cabinet to control/monitor the OCS switches.

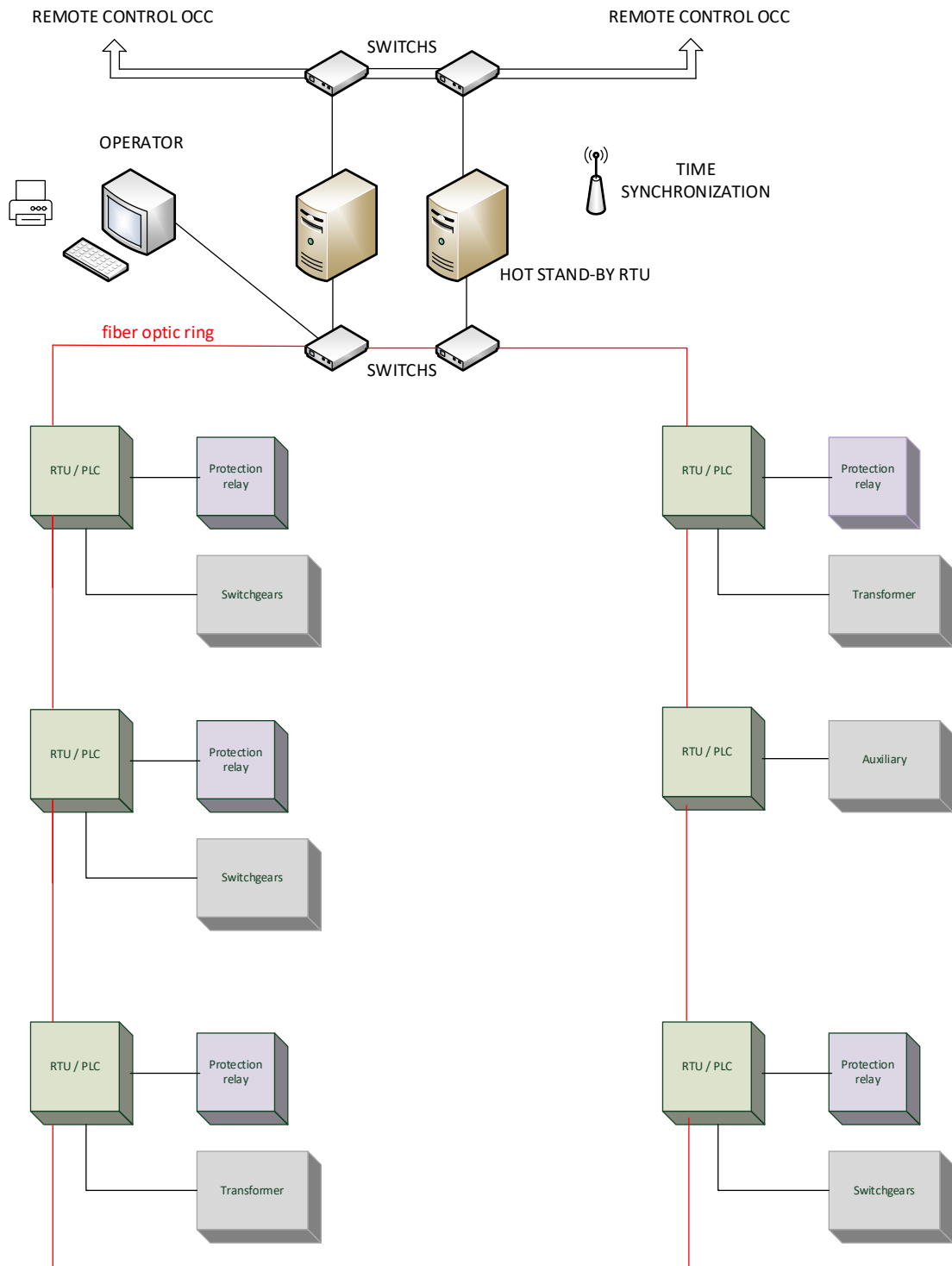

Local compartment configuration shall allow:

- Interlocks;
- Alarms;
- Local and remote commands;
- Communication management

- Integrations with IED
- Compartment diagnostic
- Protection

Refer to RBDG-MAN-024_RailwaySCADA.

3.10. Non-traction power system

RBDG-MAN-020 Railway Energy Part 3 Non-traction power supply.

3.11. Protection against fire

3.11.1. General fire protection rules

Electrical equipment shall present no fire risk for neighbouring materials. The manufacturers' instructions shall be observed in addition to the requirements of this document.

The following rules shall be at least applicable in addition to RBDG-MAN-012 general requirements:

- Physical separation between components within substations can provide a good level of protection against propagation and spread of fire.
- All service penetrations including cable ducts and routes shall be fire sealed
- Electrical equipment shall present no fire risk for neighbouring materials
- Openings into buildings between external transformers and switch rooms shall be closed off with fire board to give a degree of separation equivalent to the surrounding structure
- Toxic gases during combustion shall be avoided by adapted equipment;
- In technical rooms, only dry transformers are allowed to be installed (Oil-immersed transformers are prohibited).
- Transformers containing PCBs are prohibited.
- The technical rooms shall be equipped by a fire safety system with an OCC's report.
- Active fire suppression systems shall only be included in the design where it has not been possible to reduce the fire risk to an acceptable level by other means.

3.11.2. Additional fire protection rules for transformers

The protection against fire of flammable liquid dielectric transformers, regardless of their power and location, shall be ensured by the installation of the following devices:

- Protection against internal faults controlling the disconnection of the supply of the transformer;
- installation of a container or other item of equipment to recover all of the dielectric;
- provisions that ensure that, if the liquid dielectric spills and ignites, it extinguishes itself rapidly
- maintaining a minimum safety distance (G) between the transformer and a building or another transformer (see here below);
- if this distance cannot be respected, constructing fire-resistant partitions (see here below);

The dielectric recovery equipment shall be watertight and designed to withstand temperature rises caused by the ignited dielectric and the dielectric type.

Where a recovery equipment is common to several transformers, it shall be designed in such a way as to prevent the spread of fire from one transformer to another. Fire-break siphons shall be used for this purpose where the evacuation pipes to the recovery tank are less than 15 m in length.

All precautions shall be taken to ensure that the recovery tanks do not fill up with water. The separation of oil and water shall be ensured in the recovery tanks by using suitable equipment.

A fire on a transformer shall not expose neighbouring transformers to the risk of fire. For this purpose, the transformer shall be installed at a safety distance (G) from the transformers.

Power rating (MVA)	Safety distance (G in m)	
	Type O1 liquid dielectric	Type K2 or K3 liquid dielectric
Above 1.25 and up to 10	3	1.5
Above 10 and up to 40	5	2.5
Above 40 and up to 200	10	5
Above 200	15	7.5

O1 Mineral oil

K2 Esters

K3 Silicones

Where the safety distance (G) cannot be complied with, an EI 60 or REI 60 fire-resistant partition shall be erected in accordance with the provisions of Figure here below.

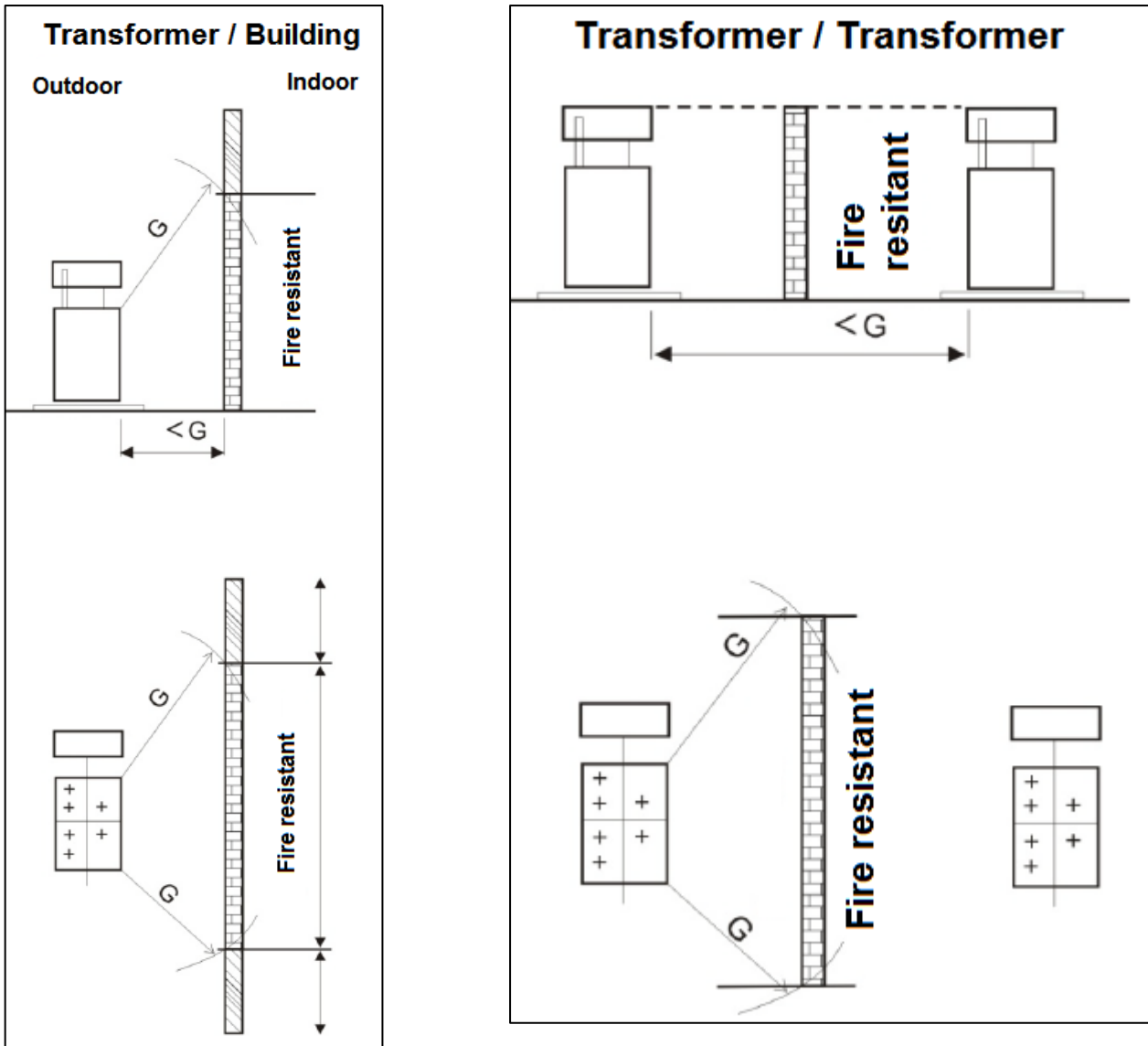

3.12. Electromagnetic compatibility

Please refer to document RBDG-MAN-021 Railway Energy Part 4 Electromagnetic compatibility.

In this section the best practices of EMC for TPS system are outlined. In addition, the limit exposures of EMC emissions are given in accordance to International Standards.

3.12.1. Best practices

- Proper grounding is necessary for human protection and noise reduction as well. Therefore, all metal framework parts shall be connected to the same reference ground potential;
- At low and high frequencies, ground connection shall be as much lower as possible;
- Control and power equipment must be kept as much physical distance as possible. The best way to separate control and power equipment is to have different cabinets.

- In the TPS, cables may be classified in four groups I, II, III and IV:
 - Group I: very sensitive to noise (analog signals, measurement cables)
 - Group II: sensitive (digital signals, sensor lines, communication signals like field buses)
 - Group III: noise source (unswitched power lines)
 - Group IV: strong noise sources (output cables from inverters, switched power circuits)

The following principles shall be respected:

- Spacing as much as possible groups I, II and III, IV
- Groups I and II should be shielded if necessary;
- If possible groups I, II and III, IV should be installed in different cable trays or at least a cable tray with a metal partition;
- Cables of groups I, II and III, IV must always intersect at right angles

3.12.2. Limits exposures

A feature of SS is that the load can change widely in short times. Since emission can be related to load, the actual loading of the substation shall be noted during emission tests.

Radio frequency noise emission from SS to the outside environment shall not exceed the limits in Figure 2 of EN50121-2 Standard.

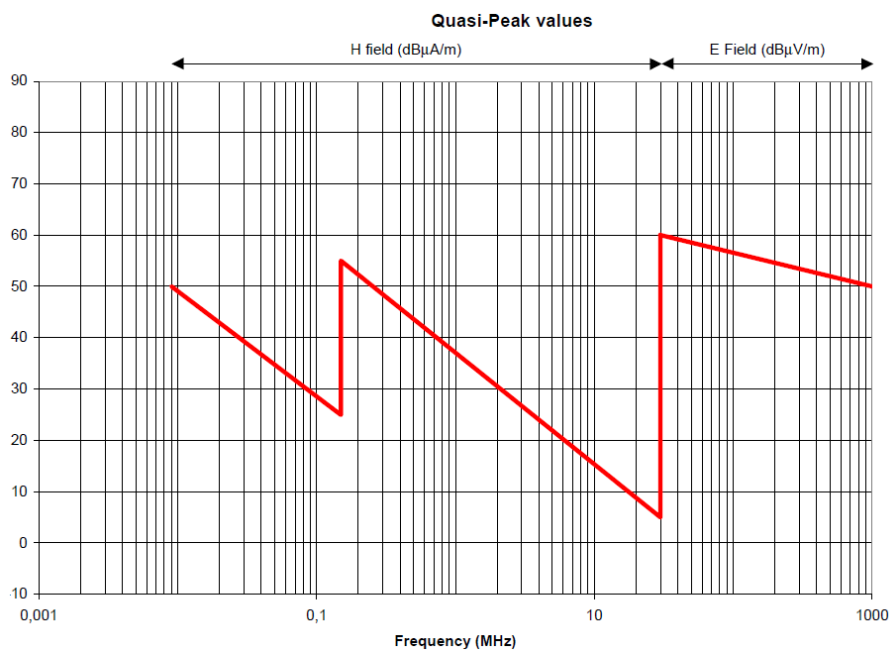

For lower frequencies noise emissions from SS to the outside environment shall not exceed the limits of table 6 (for occupational exposure) and Table 7 (for general public) of ICNIRP GUIDELINES "FOR LIMITING EXPOSURE TO TIME-VARYING ELECTRIC, MAGNETIC AND ELECTROMAGNETIC FIELDS".

Table 6. Reference levels for occupational exposure to time-varying electric and magnetic fields (unperturbed rms values).^a

Frequency range	E-field strength (V m ⁻¹)	H-field strength (A m ⁻¹)	B-field (μT)	Equivalent plane wave power density S_{eq} (W m ⁻²)
up to 1 Hz	—	1.63×10^5	2×10^5	—
1–8 Hz	20,000	$1.63 \times 10^5/f^2$	$2 \times 10^5/f^2$	—
8–25 Hz	20,000	$2 \times 10^4/f$	$2.5 \times 10^4/f$	—
0.025–0.82 kHz	$500/f$	$20/f$	$25/f$	—
0.82–65 kHz	610	24.4	30.7	—
0.065–1 MHz	610	$1.6/f$	$2.0/f$	—
1–10 MHz	$610/f$	$1.6/f$	$2.0/f$	—
10–400 MHz	61	0.16	0.2	10
400–2,000 MHz	$3f^{1/2}$	$0.008f^{1/2}$	$0.01f^{1/2}$	$f/40$
2–300 GHz	137	0.36	0.45	50

Table 7. Reference levels for general public exposure to time-varying electric and magnetic fields (unperturbed rms values).^a

Frequency range	E-field strength (V m ⁻¹)	H-field strength (A m ⁻¹)	B-field (μT)	Equivalent plane wave power density S_{eq} (W m ⁻²)
up to 1 Hz	—	3.2×10^4	4×10^4	—
1–8 Hz	10,000	$3.2 \times 10^4/f^2$	$4 \times 10^4/f^2$	—
8–25 Hz	10,000	$4,000/f$	$5,000/f$	—
0.025–0.8 kHz	$250/f$	$4/f$	$5/f$	—
0.8–3 kHz	$250/f$	5	6.25	—
3–150 kHz	87	5	6.25	—
0.15–1 MHz	87	$0.73/f$	$0.92/f$	—
1–10 MHz	$87/f^{1/2}$	$0.73/f$	$0.92/f$	—
10–400 MHz	28	0.073	0.092	2
400–2,000 MHz	$1.375f^{1/2}$	$0.0037f^{1/2}$	$0.0046f^{1/2}$	$f/200$
2–300 GHz	61	0.16	0.20	10

3.13. Traction Power Facilities and Associated Sites

The size of the TPF sites shall be determined considering the following requirements:

- Site shall accommodate all of the equipment necessary for the level of service, associated roadway, and right-of-way requirements.
- Design requirements imposed by utility companies and/or the local jurisdictional entities
- Space provisions for future equipment (requirement of 25% - lower spare values shall be justified to the client). Space requirements for the placement and removal of equipment

Access to each TPF site shall be required both during construction and for operation and maintenance purposes. Access roads leading to/from the TPF shall be designed in accordance with the local Standards.

For traction power substations, there can be need of two accesses (as example: TSO shall have an independent access to TSO area of the traction power substation).

The design of the access roads shall take into account the heaviest and largest equipment.

The design of the equipment arrangement within the TPF shall be carried out in order to facilitate maintenance activities (working clearances).

The design of the foundations for all of the equipment and structural steel located at the TPF shall meet the local standards.